

**Maße**  
**Dimensions**  
**Encombremet • Dimensioni**  
**Dimensiones • Габариты крана**

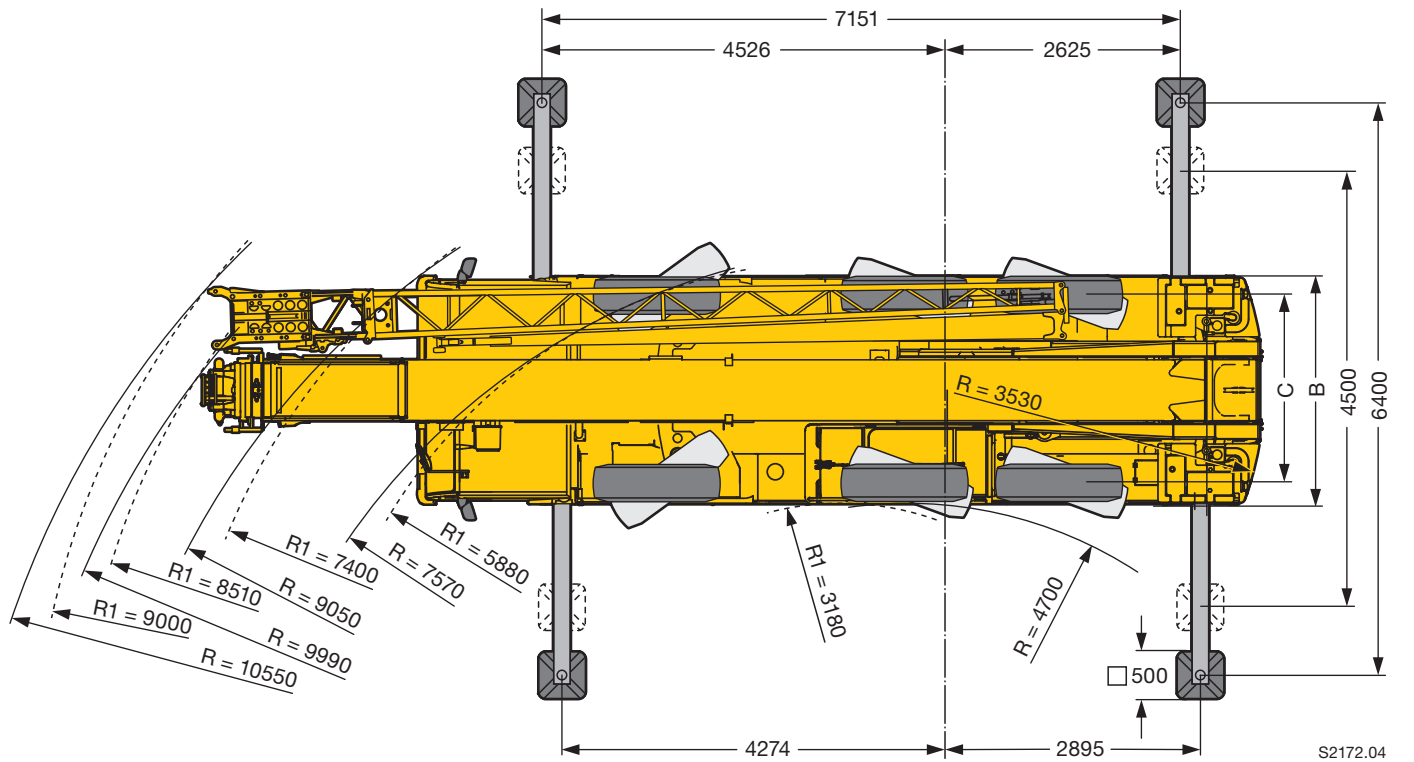
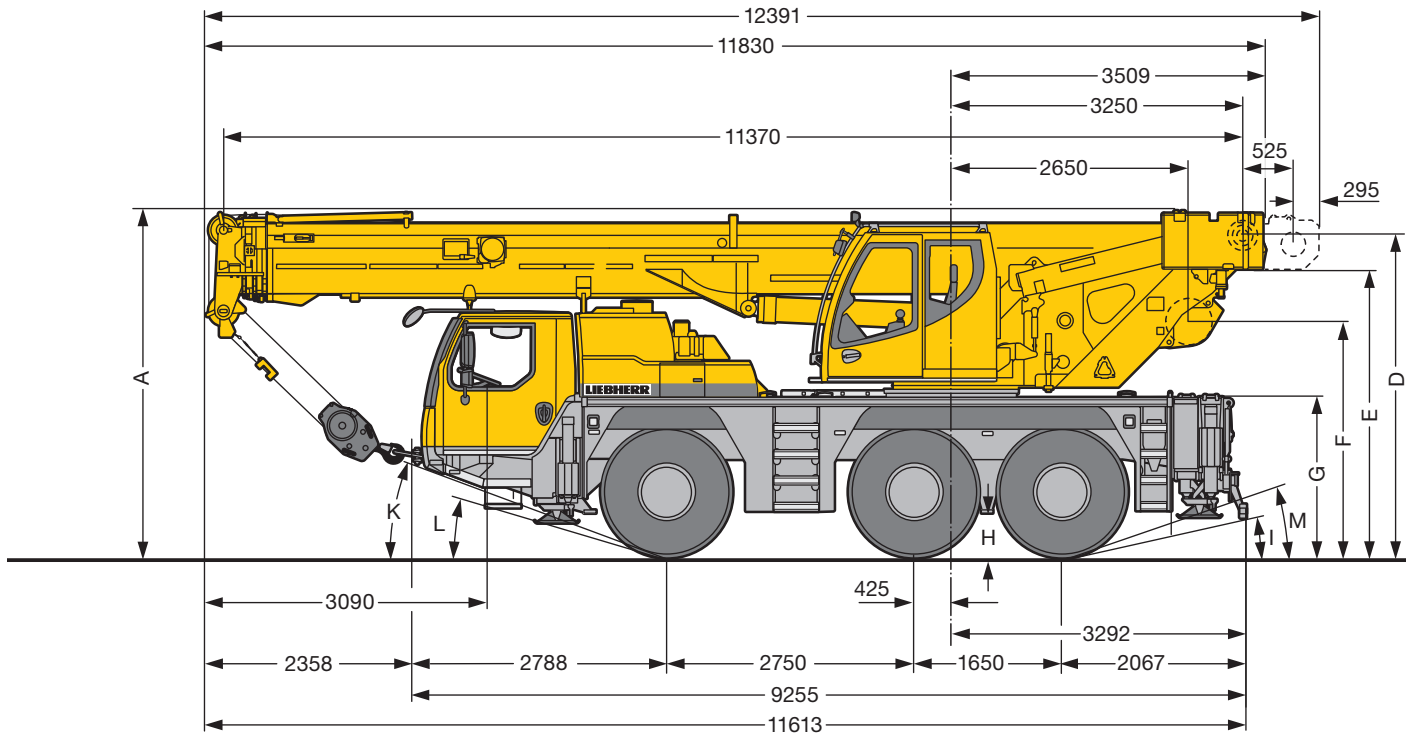

R<sub>1</sub> = Allradlenkung · All-wheel steering · Direction toutes roues · Tutti gli assi sterzanti · Dirección en todos los ejes · Поворот всеми колесами

Maße · Dimensions · Encombremet · Dimensioni · Dimensiones · Размеры mm

	A	A 100 mm*	B	C	D	E	F	G	H	I	K	L	M
385/95 R 25 (14.00 R 25)	3785	3685	2550	2113	3508	3131	2548	1710	375	11°	19°	13°	17°
445/95 R 25 (16.00 R 25)	3835	3735	2550	2101	3558	3181	2598	1760	425	12°	21°	15°	19°
525/80 R 25 (20.5 R 25)	3835	3735	2690	2163	3558	3181	2598	1760	425	12°	21°	15°	19°

\* abgeseckt · lowered · abaissé · abbassato · suspensión abajo · шасси осажено

# Hubhöhen

## Lifting heights

Hauteurs de levage • Altezze di sollevamento

Alturas de elevación • Высота подъема

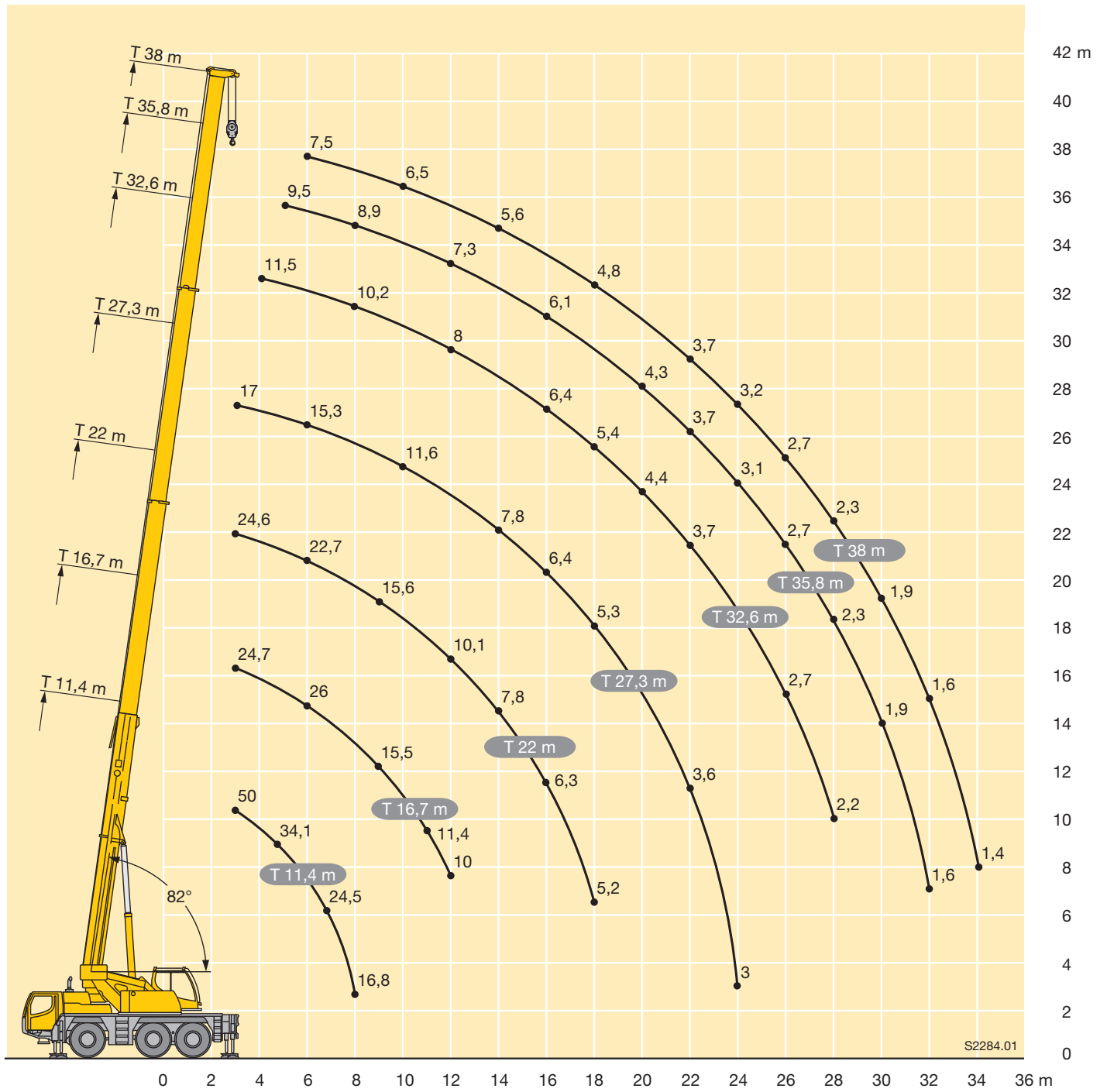

S2284.01

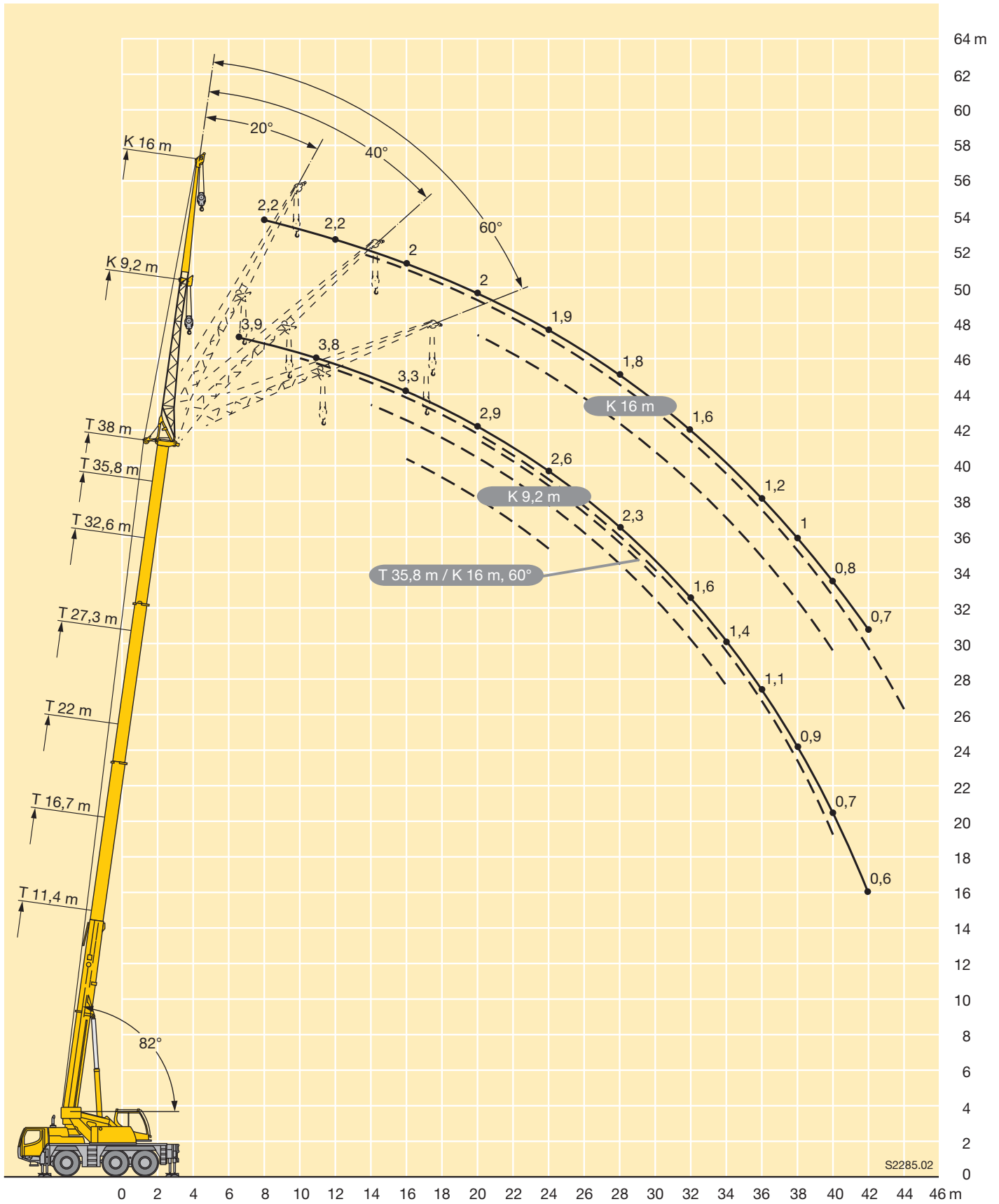

S2285.02

